

## RACK & PINION

**B**y shrinking the pinion with helical teeth, hardened and ground, through advanced technologies, or with SIT-LOCK® locking device, we are able to propose a system of power transmission compact and quiet.

Thanks to precise mating pinion racks with helical teeth hardened and ground, made in different materials and heat treatments designed for every need technical application, we are able to meet the increasingly high demands in terms of dynamics and precision.



## Rack – Model Code

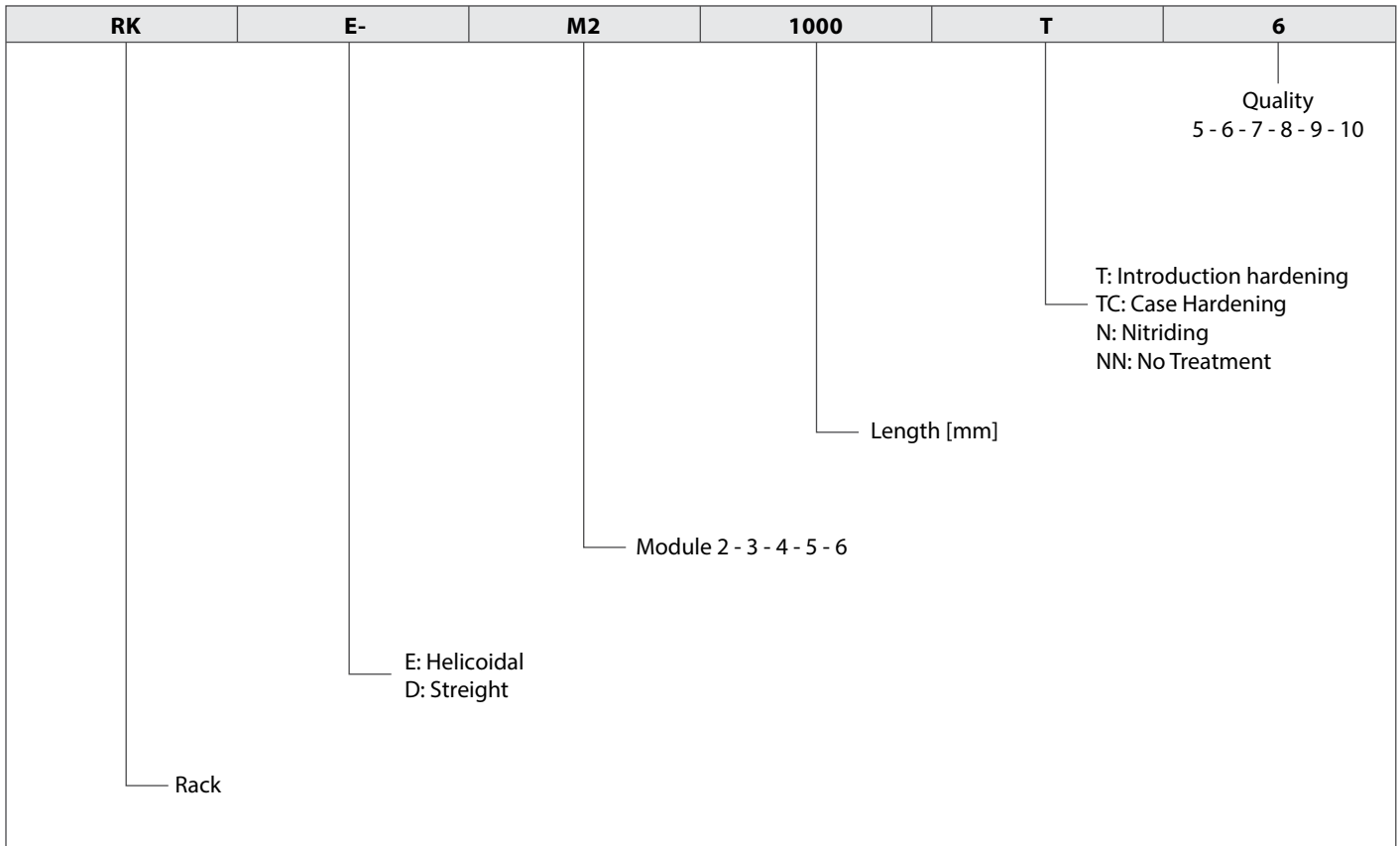

## Rack & Pinion – Model Code

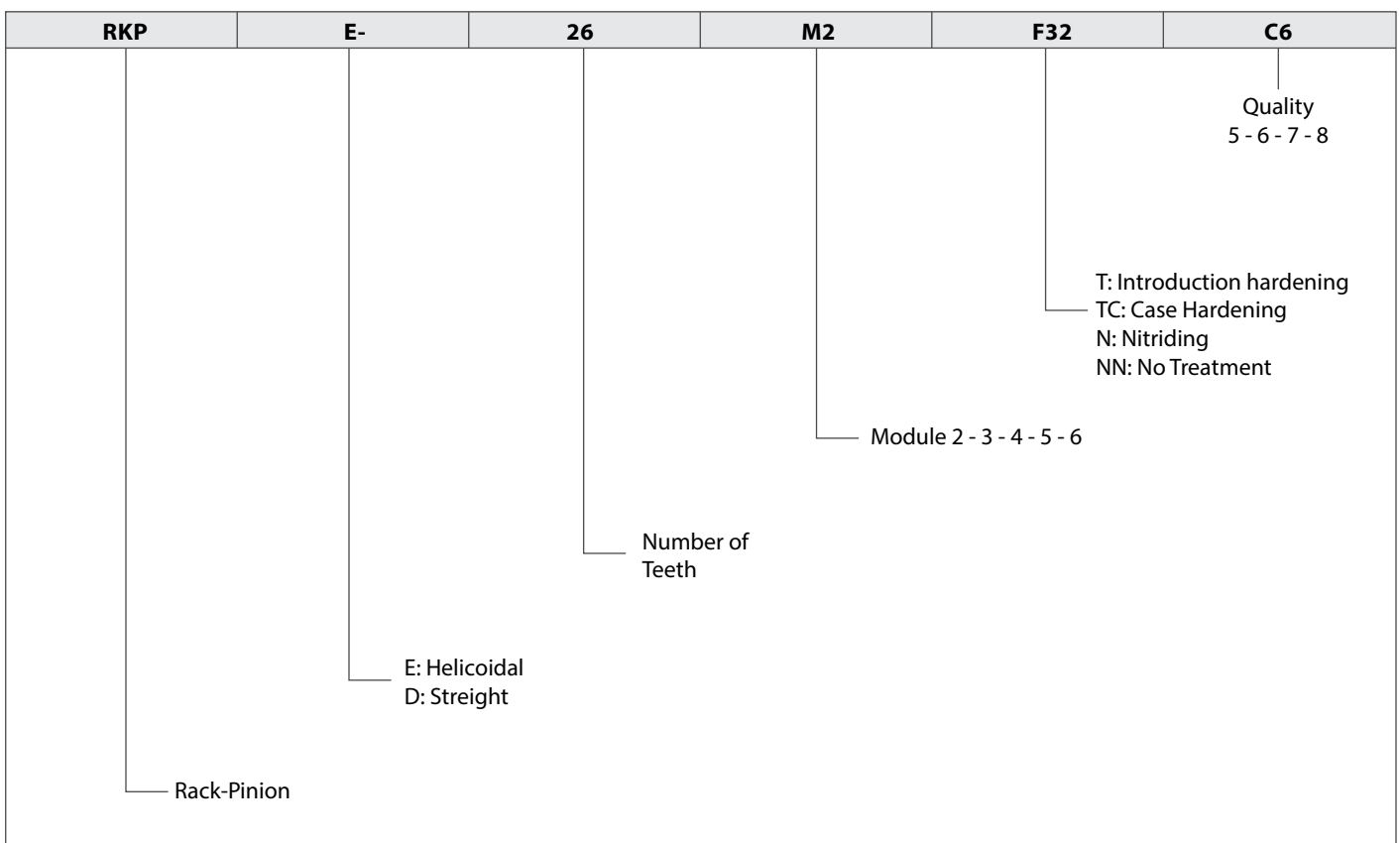

## Rack & Pinion transmission system precise and compact

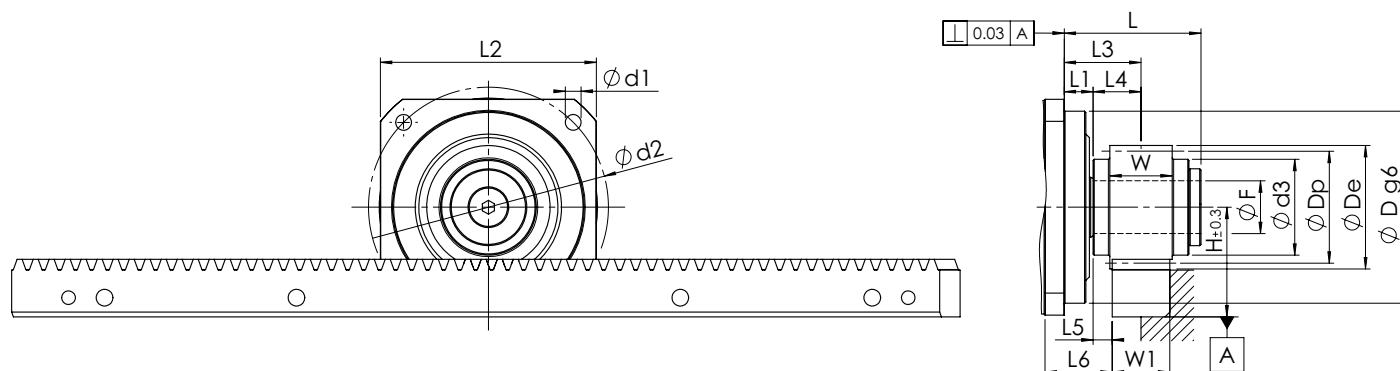

### VRB Series

Size	M	z	H* [mm]	W [mm]	W1 [mm]	De [mm]	Dp [mm]	x [mm]	Dg6 [mm]	d1 [mm]	d2 [mm]	d3 [mm]	L1 [mm]	L2 [mm]	L [mm]	L3 [mm]	L4 [mm]	L5 [mm]	L6 [mm]	ØF [mm]	Pinion Weight [Kg]
VRB060B	2	18	4189	26	24	43,80	38,20	0,4	50	5,5	70	30	9	60	43	28	19	1	22	16	0,2
VRB090B	2	20	4402	26	24	48,041	42,44	0,4	80	6,6	100	36	12	90	55	37	25	13	33	22	0,3
VRB090B	2	22	45,73	26	24	51,46	46,69	0,2	80	6,6	100	40	12	90	55	32	20	8	28	22	0,4
VRB115B	2	26	49,58	26	24	59,17	55,17	0	110	9	130	45	7	115	74	28	21	9	26	32	0,5
VRB115B	3	25	65,79	31	29	85,58	79,58	0	110	9	130	60	7	115	74	28,5	21,5	7	24	32	1,5
VRB140B	3	24	64,19	31	29	82,39	76,39	0	130	11	165	58	15	140	107	50,5	35,5	21	48	40	1,2
VRB140B	4	21	79,56	40	39	97,13	89,13	0	130	11	165	62	15	140	107	79	64	44,5	71,5	40	2
VRB180B	4	24	85,93	40	39	109,86	101,86	0	160	13,5	215	80	23	180	116	87	64	44,5	82,5	55	2,6

### VRS Series

Size	M	z	H [mm]	W [mm]	W1 [mm]	De [mm]	Dp [mm]	x [mm]	Dg6 [mm]	d1 [mm]	d2 [mm]	d3 [mm]	L1 [mm]	L2 [mm]	L [mm]	L3 [mm]	L4 [mm]	L5 [mm]	L6 [mm]	ØF [mm]	Pinion Weight [Kg]
VRS075B	2	18	41,89	26	24	43,80	38,20	0,4	60	5,5	68	30	20	60	54	39	19	7	33	16	0,2
VRS075B	2	20	44,02	26	24	48,041	42,44	0,4	70	6,6	85	36	20	75	63	45	25	13	40	22	0,3
VRS075B	2	22	45,73	26	24	51,46	46,69	0,2	70	6,6	85	40	20	75	63	40	20	8	35	22	0,4
VRS100B	2	26	49,58	26	24	59,17	55,17	0	90	9	120	45	30	100	97	51	21	9	49	32	0,5
VRS100B	3	25	65,79	31	29	85,58	79,58	0	90	9	120	60	30	100	97	51,5	21,5	7	47	32	1,5
VRS140B	3	24	64,19	31	29	82,39	76,40	0	130	11	165	58	30	140	122	65,5	35,5	21	63	40	1,2
VRS140B	4	21	79,56	40	39	97,13	89,13	0	130	11	165	62	30	140	122	94	64	44,5	86,5	40	2
VRS180B	4	24	85,93	40	39	109,86	101,86	0	160	13,5	215	80	30	160	123	94	64	44,5	86,5	55	2,6

z: Number of teeth  
 De: External diameter  
 D: Primitive diameter  
 x: Correction profile

\* We recommend the use of alignment device (tolerance  $\pm 0.3$  mm)  
 Pressure angle  $\alpha = 20^\circ$   
 Helical inclination  $\beta = 19^\circ 31' 42''$  left

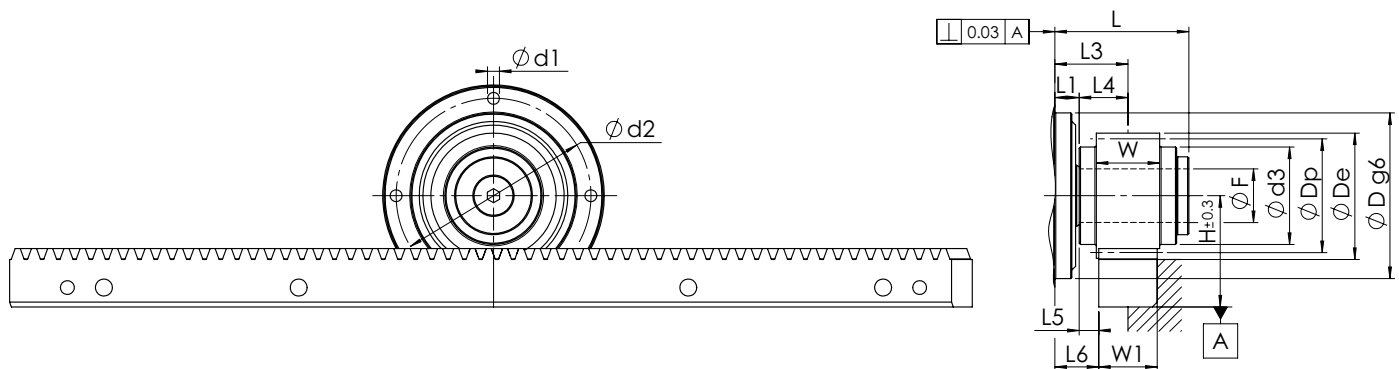

## VRL Series

Size	M	z	H* [mm]	W [mm]	W1 [mm]	De [mm]	Dp [mm]	x [mm]	D g6 [mm]	d1 [mm]	d2 [mm]	d3 [mm]	L1 [mm]	L [mm]	L3 [mm]	L4 [mm]	L5 [mm]	L6 [mm]	ØF [mm]	Pinion Weight [Kg]
VRL070B	2	18	41,89	26	24	43,80	38,20	0,4	52	M5	62	30	8	42	27	19	7	15	16	0,2
VRL090B	2	20	44,02	26	24	48,041	42,44	0,4	68	M6	80	36	10	53	35	25	13	23	22	0,3
VRL090B	2	22	45,73	26	24	51,46	46,69	0,2	68	M6	80	40	10	53	30	20	8	18	22	0,4
VRL120B	2	26	49,58	26	24	59,17	55,17	0	90	M8	108	45	12	79	33	21	9	21	32	0,5
VRL120B	3	25	65,79	31	29	85,58	79,58	0	90	M8	108	60	12	79	33,5	21,5	7	19	32	1,5
VRL155B	3	24	64,19	31	29	82,39	76,40	0	120	M10	140	58	15	107	50,5	35,5	21	36	40	1,2
VRL155B	4	21	79,56	40	39	97,13	89,13	0	120	M10	140	62	15	107	79	64	44,5	59,5	40	2
VRL205B	4	24	85,93	40	39	109,86	101,85	0	150	M12	184	80	18	111	82	64	44,5	62,5	55	2,6

z: Number of teeth  
De: External diameter  
D: Primitive diameter  
x: Correction profile

\* We recommend the use of alignment device (tolerance  $\pm 0.3$  mm)  
Pressure angle  $\alpha = 20^\circ$   
Helical inclination  $\beta = 19^\circ 31' 42''$  left

Model frame size	M	Z	Ø Hole [mm]	Motor speed [min <sup>-1</sup> ]	Ratio	Moving force [N]	Torque [Nm]	Speed [m/min.]	Weight [kg]
VRS060B VRL070B VRB060B	2	18	16/22	6000	3	950	18	240	0,2
VRS075B VRL090B VRB090B	2	22	22	6000	3	2150	50	293	0,4
VRS100B VRL120B VRB115B	2 3	26 25	32 32	6000	3	4350	120	346	0,5
VRS140B VRL155B VRB140B	3 4	24 21	40 40	4000	3	6300	240	370	1,2
VRS180 VRL205 VRB180	4	24	55	3000	3	11000	500	320	1,5

Material	Heat treatment	HRC	Quality	Surface
16 Ni Cr Mo 5	Case hardening and induction hardening	60	Q5- Q6-Q7	Grinding
18 Ni Cr Mo 5	Case hardening and induction hardening	60	Q5-Q6-Q7	Grinding
C 45	Induction hardening	55-57	Q6-Q7	Grinding
31 Cr Mo 12	Nitriding	55	Q8	Milling

## Precision helicoidal teeth

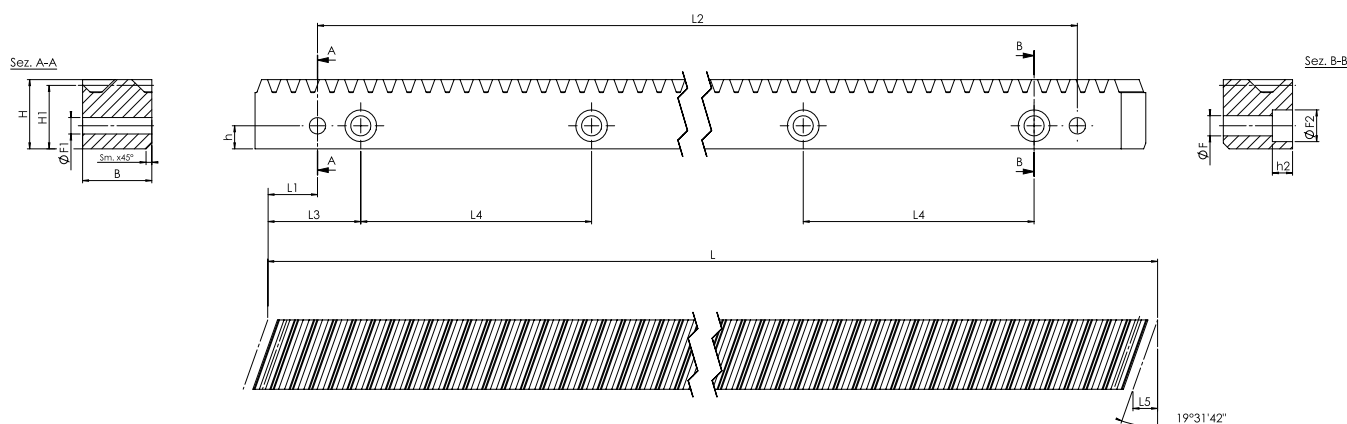

M	Pt [mm]	Single step error [mm]	Total step error [mm]	L [mm]	Z	L <sub>1</sub> * [mm]	L <sub>2</sub> [mm]	B [mm]	F [mm]	F <sub>1</sub> [mm]	F <sub>2</sub> [mm]	Sm. <sup>+0.5</sup> [mm]	H1 [mm]	h [mm]	h <sub>2</sub> [mm]	H [mm]	L <sub>3</sub> [mm]	L <sub>4</sub> [mm]	L <sub>5</sub> [mm]	Weight [Kg]
2	6,67	0,008	0,035	1000	150	31,7	936,6	24	7	5,7	11	2	22	8	7	24	62,5	125	8,5	4
3	10	0,009	0,035	1000	100	35	930	29	10	7,7	15	2	26	9	9	29	62,5	125	10,3	5,6
4	13,33	0,009	0,035	1000	75	33,3	933,4	39	10	7,7	15	3	35	12	9	39	62,5	125	13,8	10,3
5	16,67	0,01	0,040	1000	60	37,5	925	49	14	11,7	20	3	34	12	13	39	62,5	125	17,4	12,2
6	20	0,01	0,040	1000	50	37,5	925	59	18	15,7	26	3	43	16	17	49	62,5	125	20,9	18,3

\* The installation of more racks determines the presence of gaps between the segments

Pt: Trasverse Pitch

Material	Heat treatment	HRC	Quality	Surface
16 Mn Cr 5	Case hardening and induction hardening	58-60	Q5- Q6	Grinding
C 45	Induction hardening	55-57	Q6-Q7-Q8	Grinding
C 45	Induction hardening	55-57	Q8	Milling
42 Cr Mo 4	No treatment	-	Q8	Milling
31 Cr Mo 12	Nitriding	55	Q8	Milling
C 45	No treatment	-	Q9-Q10	Milling