

SITEX® Teeth Coupling



**SITEX®**  
**SITEX® FL**



## Contents

<b>SITEX® Teeth Couplings</b>	<b>Page</b>
Description	29
ATEX Directive	29
Dimensional characteristics	30
SITEX® coupling selection	31
Tables for SITEX® couplings with taper or splined bores	32
SITEX® Nylex	33
<b>SITEX® FL</b>	
Description	34
Main characteristics and advantages	34
Flange dimensions in according to SAE J620	35
Special flange dimensions	36
Flywheel bell housing	36
Technical characteristics	37
Selection	37
Installation and maintenance	38
FLD execution	38
Splined bore hub	39
SITEX® FL coupling selection	40



## SITEX® teeth couplings

### Description

SITEX® couplings consist of two toothed hubs which are connected with one internally toothed sleeve. The hubs are made of steel and the teeth, which are both profiled and section crowned, are

milled. The sleeve is manufactured from stabilized 6.6 super-polyamide resin.



### Features

SITEX® couplings are members of the elastic coupling family range. Sitex couplings are well suited for applications with axial, radial, and angular displacement of the connected shafts. The double cardanic action eliminates the imposition of loads on the shafts which results from radial and axial misalignment. The torsional rigidity of the sleeve prevents angular speed variation.

The combination of steel hubs with Polyamide sleeve makes the coupling maintenance and lubrication free.

The particular toothed profile prevents contact of tooth edges with the sleeve, ensuring long life of the coupling.

### Performance

Mounting can be in both the horizontal and vertical planes. Installation is simple and quick, which lowers installation costs. The coupling is suitable for operating in temperatures ranging from - 25 °C to + 90 °C.

For short intervals, temperatures of + 125 °C can be tolerated. Components of the coupling are resistant to all types of lubricants and hydraulic fluids.

### ATEX Directive 2014/34/EU

It is possible to ask for specific certification for use in hazardous area according to ATEX Directive 2014/34/EU.

SITEX® couplings are available with specific mounting/operating instruction manual and conformity.

For information, please contact our technical office.



**Dimensional characteristics**

Due to compact dimensions and excellent performances, SITEX® couplings may be used in a wide range of applications. Couplings are available from stock, both the standard and the "long" hub execution, which entirely covers the motor shaft.

SITEX® hubs are available with certain stock bores as listed below. The standard solid hub has a pilot center concentric to the hub OD and can be bored to specific needs.

**Approved according to ATEX Directive.**

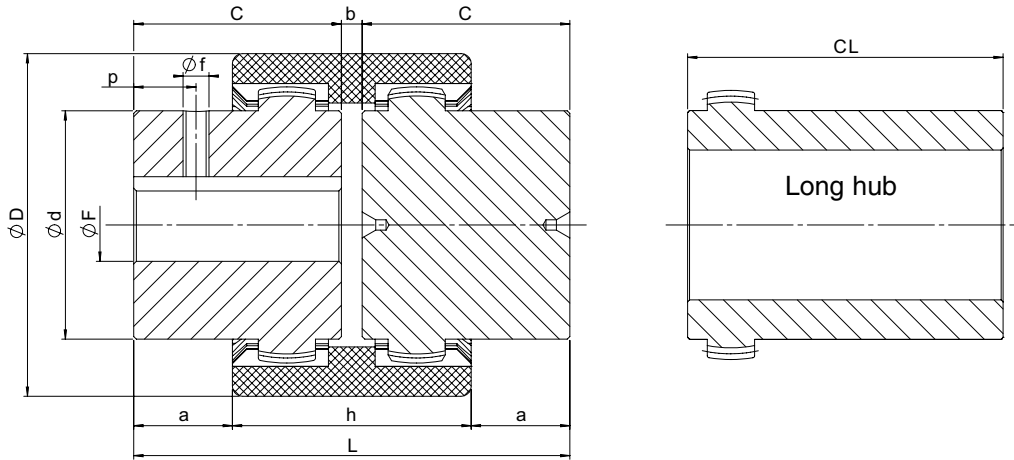

Size	D [mm]	d [mm]	F (H7)			C [mm]	CL [mm]	b [mm]	a [mm]	h [mm]	L [mm]	f [mm]	p [mm]
			min	max	UNI keyway and set-screw* [mm]								
14	40	24,5	8	14	11 - 14	23	30	4	6,5	37	50	M5	6
19	48	30	8	19	11 - 14 - 19	25	-	4	8,5	37	54	M5	6
24	52	35	11	24	14 - 19 - 20 - 22 - 24	26	50	4	7,5	41	56	M5	6
28	66	43	11	28	16 - 19 - 22 - 24 - 28	40	60	4	18,5	47	84	M8	10
32	76	50	14	32	22 - 24 - 28 - 32	40	60	4	17,5	48	84	M8	10
38	83	58	14	38	24 - 28 - 32 - 38	40	80	4	18	48	84	M8	10
42	92	65	14	42	25 - 28 - 32 - 38 - 42	42	110	4	18,5	51	88	M8	10
48	100	68	19	48	32 - 38 - 42 - 48	50	110	4	27	50	104	M8	10
65	142	96	19	65	38 - 42 - 48 - 55 - 60	70	140	4	35,5	73	144	M10	20
80	175	124	-	80	-	90	-	6	46,5	93	186	M10	20
100	210	152	36	100	-	110	-	8	63	102	228	M10	20
125	270	192	45	125	-	140	-	10	78	134	290	M10	20

\* = Up to size 24, set-screw is 180° from keyway; from size 28 set-screw is set onto the keyway. Keyway according to DIN 6885 sheet 1 - JS9

**Order form**

Hub **GDM 48 F32**

GDM: SITEX® hub

Size

L: long hub execution  
F...: bore diameter

Sleeve **AD 48**

AD: SITEX® sleeve

Size

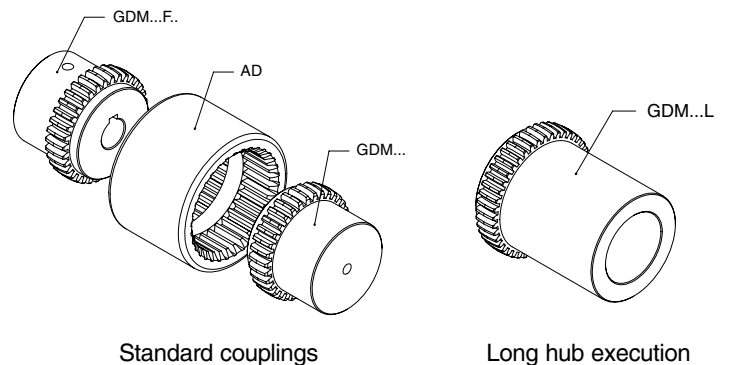

# SITEX® coupling selection

## Selection according to torque

The maximum starting torque of the driver or driven machine must not exceed the maximum torque capacity of SITEX®. With uniform loading and well aligned shafts, SITEX® can be

operated at all torques up to the maximum. In case of irregular torque, consider that the SITEX® coupling can bear peak loads up to 3 times the nominal torque indicated.

## Technical characteristics

Size	T <sub>KN</sub> [Nm]	T <sub>Kmax</sub> [Nm]	T <sub>Kw</sub> [Nm]	[kW]										n <sub>max</sub> [min <sup>-1</sup> ]	W* [kg]	J* [kg.m <sup>2</sup> ]	ΔK <sub>a</sub> [mm]	ΔK <sub>r</sub> [mm]	ΔK <sub>w</sub> [°]
				n = 500 [min <sup>-1</sup> ]		n = 750 [min <sup>-1</sup> ]		n = 1000 [min <sup>-1</sup> ]		n = 1500 [min <sup>-1</sup> ]		n = 3000 [min <sup>-1</sup> ]							
				std	max	std	max	std	max	std	max	std	max						
14	10	30	5	0,5	1,6	0,8	2,4	1,0	3,1	1,6	4,7	3,1	9,4	14.000	0,18	0,000026	±1	±0,3	±1
19	16	48	8	0,8	2,5	1,3	3,8	1,7	5,0	2,5	7,5	5,0	15,1	11.800	0,24	0,000054	±1	±0,3	±1
24	21	63	10,5	1,1	3,3	1,6	4,9	2,2	6,6	3,3	9,9	6,6	19,8	10.500	0,30	0,000088	±1	±0,3	±1
28	45	135	22,5	2,4	7,1	3,5	10,6	4,7	14,1	7,1	21,2	14,1	42,4	8.500	0,73	0,000312	±1	±0,4	±1
32	60	180	30	3,1	9,4	4,7	14,1	6,3	18,8	9,4	28,3	18,8	56,5	7.600	0,99	0,000572	±1	±0,4	±1
38	81	243	40,5	4,2	12,7	6,4	19,1	8,5	25,4	12,7	38,2	25,4	76,3	6.700	1,20	0,000877	±1	±0,4	±1
42	100	300	50	5,2	15,7	7,9	23,6	10,5	31,4	15,7	47,1	31,4	94,2	6.000	1,62	0,001467	±1	±0,4	±1
48	142	426	71	7,4	22,4	11,2	33,6	14,9	44,8	22,3	67,1	44,6	134,3	5.580	1,79	0,001869	±1	±0,4	±1
65	380	1140	190	19,9	59,7	29,8	89,5	39,8	119,4	59,7	179,1	119,4	358,1	4.000	5,28	0,010542	±1	±0,6	±1
80	700	2100	350	36,6	109,9	55,0	164,9	73,3	219,9	109,9	329,8	219,9	659,7	3.100	11,7	0,036774	±1	±0,7	±1
100	1210	3630	605	63,4	190,1	95,0	285,1	126,7	380,1	190,1	570,2	380,1	1140,3	3.000	20,4	0,095742	±1	±0,8	±1
125	2500	7500	1250	130,9	392,7	196,3	589,0	261,8	785,3	392,7	1178,0	-	-	2.100	43,3	0,329397	±1	±1,1	±1

\*= Values are for complete couplings, max bore diameter, only.

The values shown in the table for radial and angular misalignment, must be adjusted in cases where they are simultaneously acting on the coupling.

The sum of the admissible value (A) and the respective values shown in the table must be lower or equal to 1.

$$\frac{\Delta K_{rA}}{\Delta K_r} + \frac{\Delta K_{wA}}{\Delta K_w} \leq 1$$

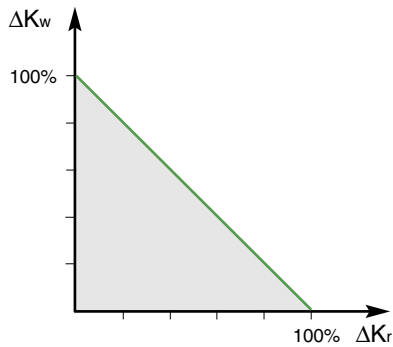

T <sub>KN</sub>	Coupling nominal torque	Nm
T <sub>Kmax</sub>	Coupling maximum torque	Nm
W	Weight	kg
J	Coupling moment of inertia	kgm <sup>2</sup>
ΔK <sub>a</sub>	Maximum axial misalignment	mm
ΔK <sub>r</sub>	Maximum radial misalignment	mm
ΔK <sub>w</sub>	Maximum angular misalignment	°
n <sub>max</sub>	Maximum rpm	min <sup>-1</sup>

## Mounting instructions

- Attach the hubs to the shafts, taking care to align the inner surfaces with the corresponding shaft ends.
- Insert the sleeve on the two hubs adjusting the distance (dimension "b") of the same ones trying at the same time to align the two shafts as much as possible.

- Tighten into position the two elements to be coupled.
- Before rotating the coupling, be sure the sleeve is free to move axially.

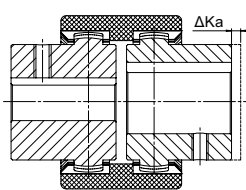

axial misalignment

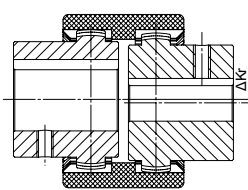

radial misalignment

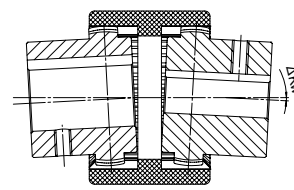

angular misalignment

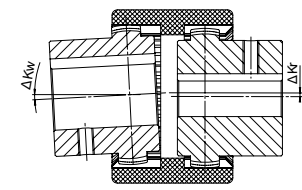

both angular and radial misalignment

## Tables for SITEX® couplings with taper or splined bores

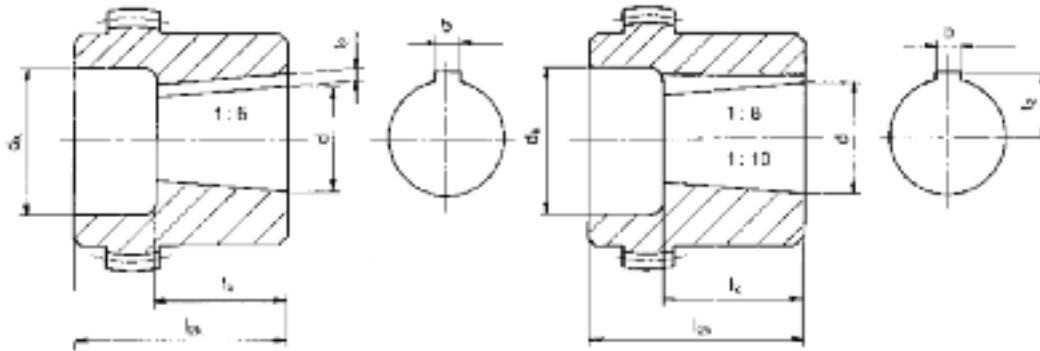

**Taper 1 : 5 for**  
BOSCH - BUCHER - LEDUC - DÜSTERLOH

Size	dø + 0,05	b <sup>JS9</sup>	t <sup>2</sup> +0,1	l <sub>k</sub>	14		19		24		28		32		38		42		48		65	
					d <sub>k</sub>	l <sub>2k</sub>	d <sub>k</sub>	l <sub>2k</sub>	d <sub>k</sub>	l <sub>2k</sub>	d <sub>k</sub>	l <sub>2k</sub>	d <sub>k</sub>	l <sub>2k</sub>	d <sub>k</sub>	l <sub>2k</sub>	d <sub>k</sub>	l <sub>2k</sub>	d <sub>k</sub>	l <sub>2k</sub>	d <sub>k</sub>	l <sub>2k</sub>
a1	9,85	2	1	11,5	18	23	22	25	24	26	35	26	36	26	45	26						
a2	16,85	3	1,8	18,5			25	30	28	30	35	40	36	40	45	40	45	42	45	42	45	50
a3	19,85	4	2,2	21,5					28	36	35	40	36	40	45	40	45	42	45	42	45	50
a4	21,95	3	1,8	21,5					30	26	32	40	32	40	42	40	45	42				
a5	24,85	5	2,9	26,5							35	40	36	40	45	40	45	42	45	42	55	50
a6	29,85	6	2,6	31,5										45	55	45	55	45	55	55	55	55
a7	34,85	6	2,6	36,5														52	60	55	60	
a8	39,85	6	2,6	41,5														52	60	65	70	

**Taper 1 : 8 for**  
ATOS - CASAPPA - GARBE LAHMEYER - JOTTI & STROZZI - MARZOCCHI - SALAMI - SAUER-FLUID

Size	dø + 0,05	b <sup>JS9</sup>	t <sup>2</sup> +0,1	l <sub>k</sub>	14		19		24		28		32		38		42		48		65	
					d <sub>k</sub>	l <sub>2k</sub>	d <sub>k</sub>	l <sub>2k</sub>	d <sub>k</sub>	l <sub>2k</sub>	d <sub>k</sub>	l <sub>2k</sub>	d <sub>k</sub>	l <sub>2k</sub>	d <sub>k</sub>	l <sub>2k</sub>	d <sub>k</sub>	l <sub>2k</sub>	d <sub>k</sub>	l <sub>2k</sub>	d <sub>k</sub>	l <sub>2k</sub>
b1	9,7	2,4	6	17	18	26	19	25	24	26	35	30	36	30	36	30						
b2	11,6	3	7,1	16,5	18	23			26	26	32	30										
b3	13	2,4	7,3	21					26	30	32	30			32	30						
b4	14	3	8,5	17,5	20	23	24	30	24	30	32	30	36	40								
b5	14,3	3,2	8,5	19,5																		
b6	17,287	3,2	9,6	24					28	35	32	40	36	40	42	40	45	42	45	42	45	50
b7	17,287	4	10,3	24					28	35	32	40	36	40	42	40	45	42	45	42	45	50
b8	17,287	3	9,7	24					28	35					42	40			45	42		
b9	22,002	3,99	12,4	28							32	40	36	40	42	40	45	42	45	42	55	50
b10	25,463	4,78	15,1	36							34	50	36	50	42	50	45	50	45	50	55	62
b11	25,463	5	15,5	36							34	50					45	50	45	50	55	62
b12	27	4,78	15,3	32,5											42	50						
b13	28,45	6	15,1	38,5											42	60	45	60				
b14	33,176	6,38	18,8	44											44	60	45	60	45	60	55	62
b15	33,176	7	18,8	44												45	60				55	62
b16	43,057	7,95	3,378	51																		
b17	41,15	8	3,1	42															48	60	55	60

**Taper 1 : 10 for**  
PARKER HANNIFIN NMF - TEVES

Size	d ø + 0,05	b <sup>JS9</sup>	t <sup>2</sup> +0,1	l <sub>k</sub>	014		19		24		28		32		38		42		48		65	
					d <sub>k</sub>	l <sub>2k</sub>	d <sub>k</sub>	l <sub>2k</sub>	d <sub>k</sub>	l <sub>2k</sub>	d <sub>k</sub>	l <sub>2k</sub>	d <sub>k</sub>	l <sub>2k</sub>	d <sub>k</sub>	l <sub>2k</sub>	d <sub>k</sub>	l <sub>2k</sub>	d <sub>k</sub>	l <sub>2k</sub>	d <sub>k</sub>	l <sub>2k</sub>
c1	19,95	5	12,1	32							35	50			42	50	45	50	45	50		
c2	24,95	6	14,1	45									36	55			45	60	45	60	55	60
c3	29,75	8	17	50												54	60	54	60	55	70	

# SITEX® Nylex

SITEX® Nylex couplings are made of 100% Polyamide.

Two executions are available:

- **CV**: in 2 parts (1 hub and one sleeve including the hub);
- **C**: in 3 parts (2 hubs and one sleeve).

Designed for light applications, low cost and available with finished bore keyway and thread for set screw.

Temperature range: - 25 °C ÷ + 90 °C.

**Approved according to ATEX Directive.**

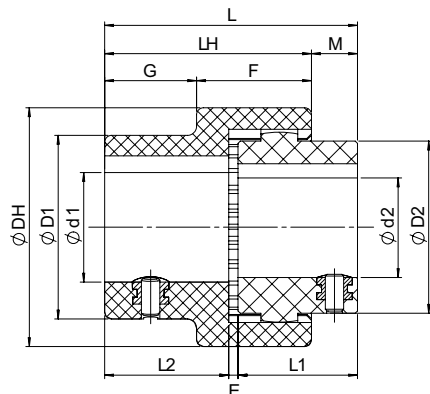

**CV**

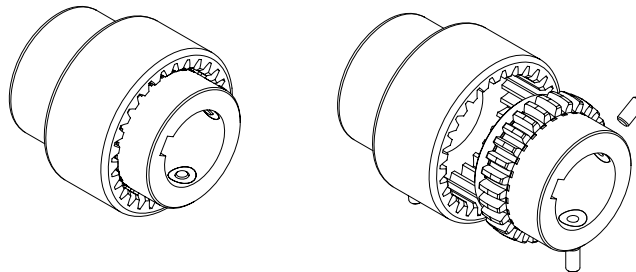

Size	d1 [mm]			D1 [mm]	d2 [mm]			D2 [mm]	DH [mm]	L1 [mm]	L2 [mm]	E [mm]	L [mm]	LH [mm]	M [mm]	F [mm]	G [mm]	TKN [Nm]	TKmax [Nm]	TKW [Nm]	nmax [min <sup>-1</sup> ]
	min	max	UNI keyway and set screw [mm]		min	max	UNI keyway and set screw [mm]														
<b>14</b>	6	14	14	25	6	14	7-9-10-11-12-14	26	40	23	23	2	48	40	8	23	17	5	10	2,5	6.000
<b>19</b>	14	19	18-19	31,5	14	19	14-17-19	40	48	25	25	2	52	42	9	23	19	8	16	4	6.000
<b>24</b>	10	24	19-20-24	37,5	10	24	10-14-16-19-20-24	40	52	26	26	2	54	45	10	25	20	12	24	6	6.000

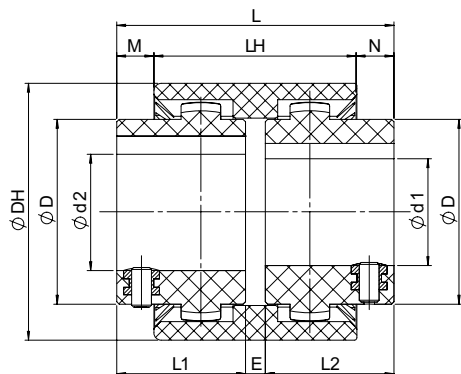

**C**

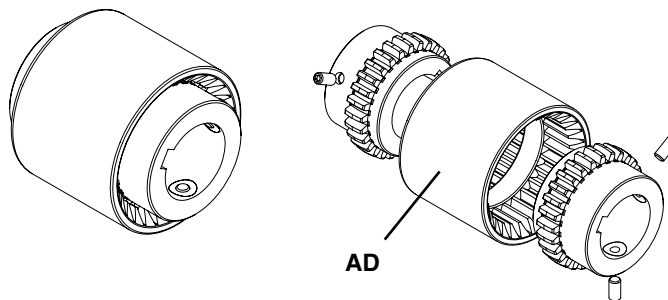

Taglia	d1-d2 [mm]			D [mm]	DH [mm]	L1 [mm]	L2 [mm]	E [mm]	L [mm]	LH [mm]	M [mm]	N [mm]	TKN [Nm]	TKmax [Nm]	TKW [Nm]	nmax [min <sup>-1</sup> ]
	min	max	UNI keyway and set screw [mm]													
<b>14</b>	6	14	7-9-10-11-12-14	25	40	23	23	4	50	37	6,5	6,5	5	10	2,5	6.000
<b>19</b>	14	19	14-17-19	31,5	48	25	25	4	54	37	8,5	8,5	8	16	4	6.000
<b>24</b>	10	24	10-14-16-19-20-24	37,5	52	26	26	4	56	41	7,5	7,5	12	24	6	6.000

## Order form

Hub **GDN 14 F14**

GDN: SITEX® NYLEX hub  
 GDNV: SITEX® NYLEX sleeve hub

Size \_\_\_\_\_

F...: bore diameter \_\_\_\_\_

"C" execution sleeve **AD 24**

AD: SITEX® NYLEX sleeve

Size \_\_\_\_\_

T <sub>KN</sub>	Coupling nominal torque	Nm
T <sub>Kmax</sub>	Coupling maximum torque	Nm
T <sub>KW</sub>	Torque with reversal transmissible by the coupling	Nm
n <sub>max</sub>	Maximum rpm	min <sup>-1</sup>

## SITEX® FL

### Description

The SITEX® FL couplings are designed for optimizing the connections between reciprocating engines and driven equipment such as pumps, compressors, generators, etc. SITEX® FL couplings consist of a steel hub and fiberglass reinforced polyamide flange which offers both mechanical strength and dimensional stability in a variety of temperature ranges.

The special teeth allow SITEX® FL couplings to compensate for small misalignments thus avoiding wear. The steel-Polyamide coupling allows maintenance free continuous operation.

**Approved according to ATEX Directive.**

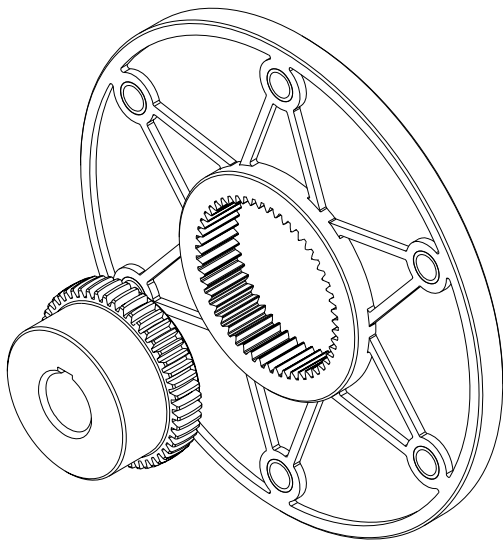

### Main characteristics and advantages

**Minimum dimensions:** The entire coupling is usually installed inside an engine housing, minimizing the axial dimensions thus reducing the tools required for installation.

**Axial misalignments:** The hub toothing can move freely axially inside the Polyamide flange avoiding axial forces which may arise on the pump shaft.

**Heat stability:** The special fiberglass reinforced Polyamide flange is designed to operate in internal combustion engine environments without air cooling and up to 140° C.

**Maintenance free:** The SITEX® FL joints are maintenance and lubrication free.

**Quick assembling:** Blind assembly makes installation of the SITEX® FL quick and easy.

**Angular misalignments:** The special teeth allow angular misalignment correction, protecting the bearings against angular forces.

**Stiffness:** The stiffness of the SITEX® FL coupling allow for torsionally vibration-free operation.

**The SITEX® FL couplings are used in connections between the flywheels of the internal combustion engines and: hydro-pumps, rotating pistons, and compressor blades.**





Flange dimensions in accordance with SAE J620

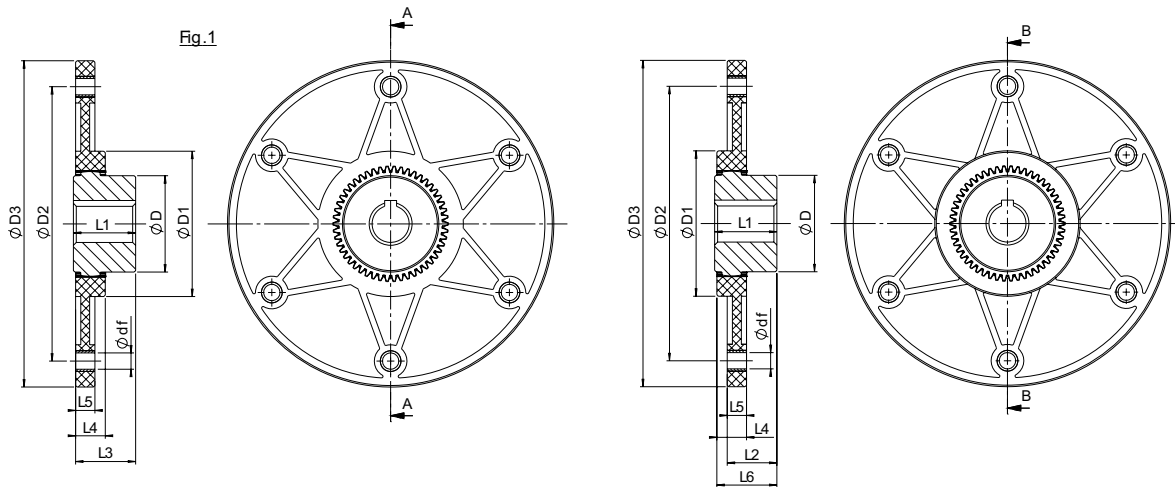

SAE flange size	Dimensions [mm]											
	Max. bore	D	D1	D2	D3	df x z	L1	L2	L3	L4	L5	L6
GDF 42 FL 6 1/2"	42	65	100	200,02	215,9	9 x 6	42	33	42	20	13	40
GDF 42 FL 7 1/2"	42	65	100	222,25	241,3	9 x 8	42	33	42	20	13	40
GDF 42 FL 8"	42	65	100	244,47	263,52	11 x 6	42	33	42	20	13	40
GDF 42 FL 10"	42	65	100	295,27	314,32	11 x 8	42	33	42	20	13	40
GDF 48 FL 6 1/2"	48	68	100	200,02	215,9	9 x 6	50	41	50	20	13	48
GDF 48 FL 7 1/2"	48	68	100	222,25	241,3	9 x 8	50	41	50	20	13	48
GDF 48 FL 8"	48	68	100	244,47	263,52	11 x 6	50	41	50	20	13	48
GDF 48 FL 10"	48	68	100	295,27	314,32	11 x 8	50	41	50	20	13	48
GDF 48P FL 6 1/2"	48	68	100	200,02	215,9	9 x 6	50	38	45	20	13	46
GDF 48P FL 7 1/2"	48	68	100	222,25	241,3	9 x 8	50	38	45	20	13	46
GDF 48P FL 8"	48	68	100	244,47	263,52	11 x 6	50	38	45	20	13	46
GDF 48P FL 10"	48	68	100	295,27	314,32	11 x 8	50	38	45	20	13	46
GDF 55 FL 7 1/2"	55	85	115	222,25	241,30	9 x 8	50	37	48	24	13	48
GDF 65 FL 8"	65	96	132	244,47	263,52	11 x 6	70	60	69	27	21	66
GDF 65 FL 10"	65	96	132	295,27	314,32	11 x 8	70	60	69	27	21	66
GDF 65 FL 11 1/2"	65	96	132	333,37	352,42	11 x 8	70	60	69	27	21	66
GDF 65P FL 8"	65	93	132	244,47	263,52	11 x 6	70	60	69	27	21	66
GDF 65P FL 10"	65	93	132	295,27	314,32	11 x 8	70	60	69	27	21	66
GDF 65P FL 11 1/2"	65	93	132	333,37	352,42	11 x 8	70	60	69	27	21	66
GDF 80 FL 11 1/2"	80	124	170	333,37	352,42	11 x 8	90	78	87	30	21	87

48P and 65P are for hubs with over-sized toothed disc.

Order form

Hub **GDM 48 F32**

GDM: SITEX® hub

Size

L: long hub execution  
F...: bore diameter

Flange **GDF 65 FL11-1/2**

GDF: SITEX® FL Flange

Bore

SAE flange size

SITEX® FL

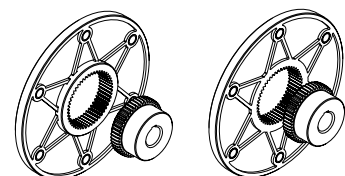

## Special flange dimensions

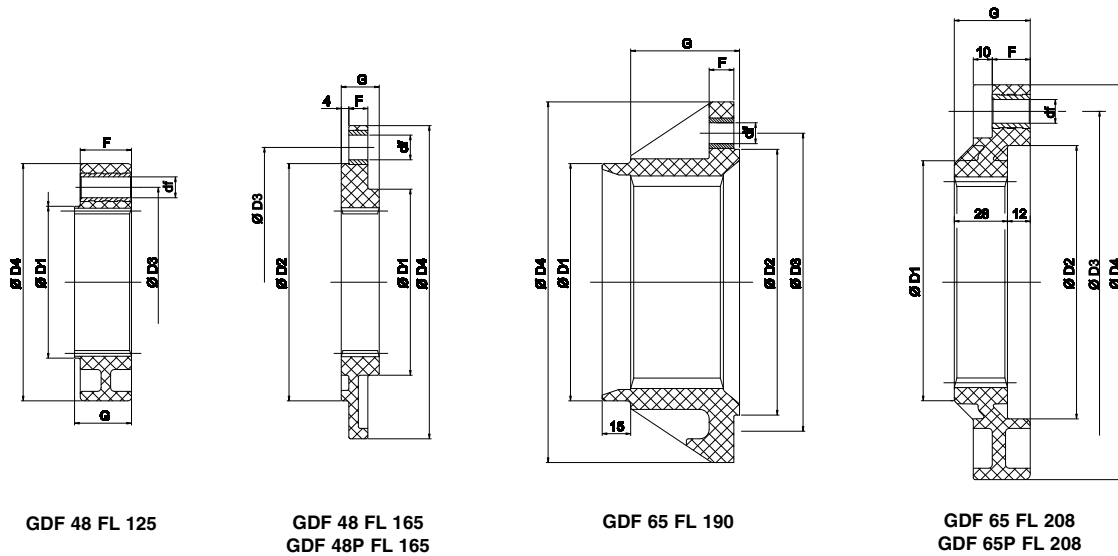

Special flange size	Max. bore	D1 [mm]	D2 [mm]	D3 [mm]	D4 [mm]	F [mm]	G [mm]	df x z
GDF 48 FL 125	48	80	-	100	125	27	30	11 x 3
GDF 48 FL 165	48	98	125	142	165	10	20	13 x 6
GDF 48P FL 165	48	98	125	142	165	10	20	13 x 6
GDF 65 FL 190	65	125	140	160	190	13	57	11 x 6
GDF 65 FL 208	65	125	144	180	208	20	40	18 x 8
GDF 65P FL 208	65	125	144	180	208	20	40	18 x 8

## Flywheel bellhousing

The dimensions of the flywheel Bell housing plates are in accordance with SAE 617.

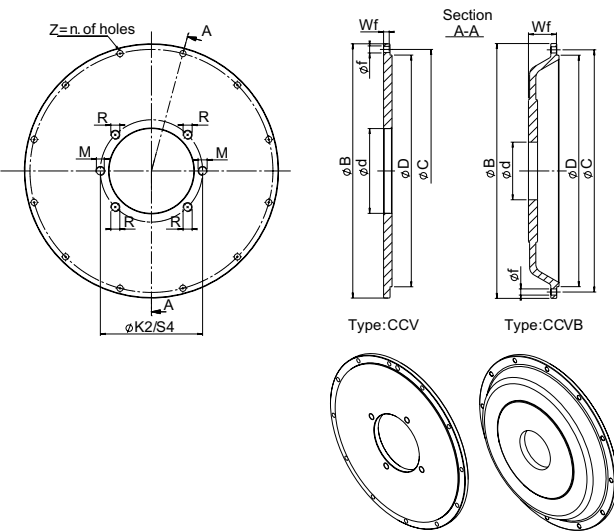

### Order form

Flywheel bell housing	CCV	6	B/4
Flywheel bellhousing	CCV	6	B/4
"B" type	B		
SAE type for engine flange			
SAE type of pump flange and number of pump mounting holes			

SAE - Flywheel Bellhousing							
SAE type	D [mm]	B [mm]	C [mm]	Number of holes Z	f [mm]	CCV	CCVB
						Wf	
SAE 6	266,7	308	285,8	8	11	10,5	-
SAE 5	314,32	356	333,4	8	11	10,5	25
SAE 4	361,95	403	381	12	11	10,5	35
							50
SAE 3	409,58	451	428,6	12	11	10,5	50
SAE 2	447,68	489	466,7	12	11	14	-

Pump assembly SAE dimensions							
SAE Pump	Center bore d [mm]	Pump mounting holes					
		n. 2 holes			n. 4 holes		
		K2	M	S4	R		
AA	50,8	82,6	M8	5/16"	-	-	-
A	82,55	106,4	M10	3/8"	104,6	M10	3/8"
B	101,6	146	M12	1/2"	127	M12	1/2"
C	127	181	M16	5/8"	162	M12	1/2"
D	152,4	228,6	M16	5/8"	228,6	M16	5/8"

# Technical characteristics

Size	Misalignment			Torque			Weight / Moment of inertia						Dynamic torsional rigidity +60 °C dampening factor [Ψ] = 0,4 [Nm/rad]				
	Axial [mm]	Angular [°]	Radial [mm]	Nominal T <sub>KN</sub> [Nm]	Max T <sub>Kmax</sub> [Nm]	Reversible T <sub>KW</sub> [Nm]	Hub		SAE SITEX® FL flange					0,25 T <sub>KN</sub>	0,50 T <sub>KN</sub>	0,75 T <sub>KN</sub>	1,00 T <sub>KN</sub>
									6-1/2"	7-1/2"	8"	10"	11-1/2"				
42	2	1°	0,2	240	600	120	Kg	0,68	0,39	0,455	0,565	0,8	-	33 x 10 <sup>3</sup>	78 x 10 <sup>3</sup>	110 x 10 <sup>3</sup>	130 x 10 <sup>3</sup>
							Kgm <sup>2</sup>	0,0006	0,003	0,004	0,006	0,011	-				
48	2	1°	0,2	250	620	125	Kg	0,75	0,4	0,52	0,5	0,75	-	33 x 10 <sup>3</sup>	78 x 10 <sup>3</sup>	110 x 10 <sup>3</sup>	130 x 10 <sup>3</sup>
							Kgm <sup>2</sup>	0,0007	0,003	0,004	0,006	0,011	-				
48 P	1	1°	0,2	310	780	155	Kg	0,85	0,4	0,52	0,5	0,75	-	38 x 10 <sup>3</sup>	88 x 10 <sup>3</sup>	125 x 10 <sup>3</sup>	148 x 10 <sup>3</sup>
							Kgm <sup>2</sup>	0,0007	0,003	0,004	0,006	0,011	-				
55	1	1°	0,2	500	1250	250	Kg	1,4	-	0,45	-	-	-	50 x 10 <sup>3</sup>	140 x 10 <sup>3</sup>	175 x 10 <sup>3</sup>	200x 10 <sup>3</sup>
							Kgm <sup>2</sup>	0,0019	-	0,0035	-	-	-				
65	2	1°	0,3	660	1650	330	Kg	2,4	-	-	0,8	0,93	1,08	58 x 10 <sup>3</sup>	142 x 10 <sup>3</sup>	205 x 10 <sup>3</sup>	250 x 10 <sup>3</sup>
							Kgm <sup>2</sup>	0,005	-	-	0,009	0,015	0,023				
65 P	1	1°	0,2	800	1950	400	Kg	2,45	-	-	0,8	0,93	1,08	76 x 10 <sup>3</sup>	185 x 10 <sup>3</sup>	270 x 10 <sup>3</sup>	330 x 10 <sup>3</sup>
							Kgm <sup>2</sup>	0,005	-	-	0,009	0,015	0,023				
80	2	1°	0,3	1300	3100	650	Kg	5,1	-	-	-	-	1,13	190 x 10 <sup>3</sup>	420 x 10 <sup>3</sup>	590 x 10 <sup>3</sup>	710 x 10 <sup>3</sup>
							Kgm <sup>2</sup>	0,015	-	-	-	-	0,023				

SITEX® FL

## Selection

For a proper sizing a safety factor k = 1,3 – 1,6 must be considered in accordance to the application. Or, the coupling nominal torque must be greater than or equal to the engine torque multiplied by k:

$$T_{KN} \geq T_N \cdot k$$

T<sub>KN</sub> = coupling nominal torque

T<sub>N</sub> = engine side torque

k = safety factor selected in accordance with the use

## Applications

## k factor

Tandem rollers.....	1,6
Asphalt processing machines.....	1,4
Agricultural machines.....	1,4
Fork lift trucks.....	1,6
Concrete Mixer.....	1,3
Self-propelled cranes.....	1,4
Excavators .....	1,4
Farm tractors.....	1,4
Road working machines.....	1,4

## Assembly

The versatility of the SITEX® FL couplings allows for numerous assembly options with different hub lengths giving consumers the ability to obtain the suitable dimension for every application.

1) Center the flange on the fly-wheel in correspondence to the seat and tighten the mounting screws DIN 912 – 8.8 class in accordance with the torque values shown in the table:

Screw	Ms
M 8	25 Nm
M 10	86 Nm
M 12	355 Nm

2) Center the fly-wheel cover plate in relation to the seat on the engine bellhousing. Tighten the screws.

3) Install the toothed hub onto the pump shaft. For split clamp hub, tighten in accordance with the torques shown in the table.

Coupling	Screw	Ms
42 - 48	M 10	49 Nm
65	M 12	86 Nm
80	M 16	355 Nm

4) Move the pump-hub assembly through the fly-wheel cover plate and up to the stop. Tighten the screws.

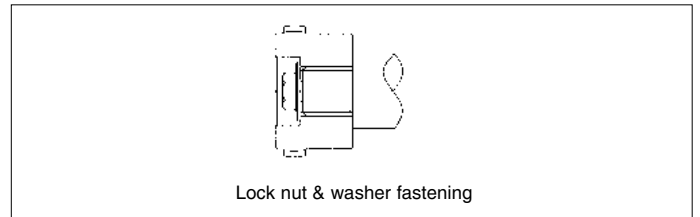
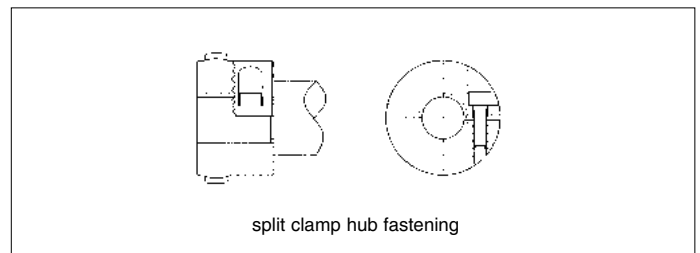
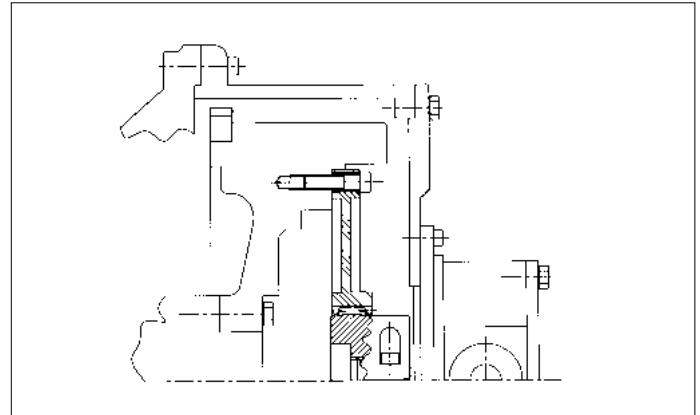

## FLD execution

The SITEX® FLD couplings are designed for applications which combine with engine pulleys. These couplings allow for belt replacement without pump disassembly. The operating temperature range is from -25 °C to 100 °C.

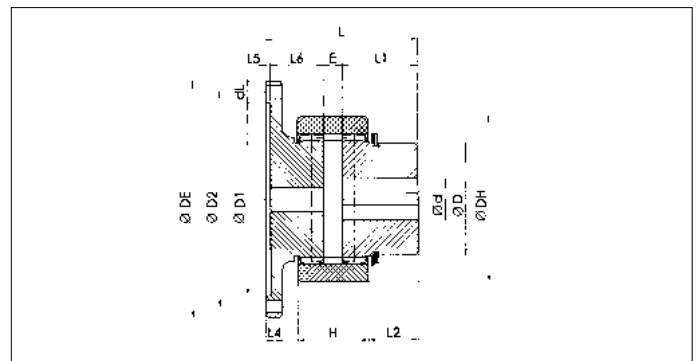

Size	T <sub>KN</sub> [Nm]	T <sub>Kmax</sub> [Nm]	T <sub>KW</sub> [Nm]	d <sub>max</sub> [mm]	L5 [mm]	L1 [mm]	L4 [mm]	L6 [mm]	E [mm]	L [mm]	H [mm]	L2 [mm]	D [mm]	DH [mm]
28 FLD	45	90	23	26	4	35,5	10	28,5	13	81	39	22,5	42	70
32 FLD	60	120	30	30	4	35,5	12	28,5	13	81	40	21,5	48	84
42 FLD	140	280	70	42	5	37,5	13	30,5	13	86	43	22,5	63	100
60 FLD	380	780	190	65	5	64	16	44	16	129	60	42	95	140
80 FLD	700	1400	350	80	6	83	20	53	20	162	69	58,5	120	175

T<sub>KN</sub> = Nominal Coupling torque T<sub>Kmax</sub> = Max Coupling torque T<sub>KW</sub> = Max reversal torque

# Splined bore hub

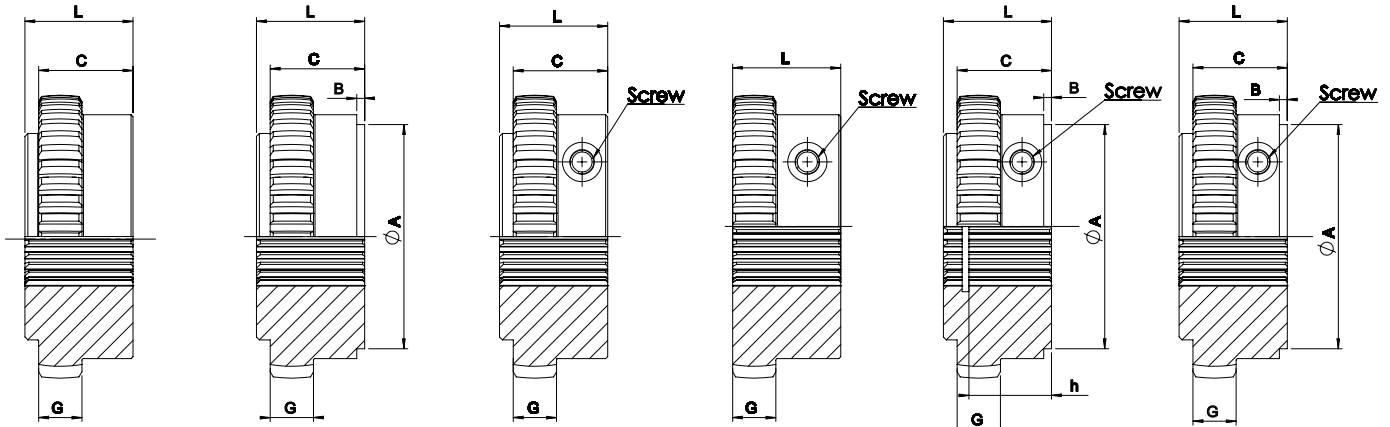

**Fig.1** Splined bore hub      **Fig.2** Splined bore hub      **Fig.3** Clamping hub with splined bore      **Fig.4** Clamping hub with splined bore      **Fig.5** Clamping hub with splined bore and seeger-ring seating      **Fig.6** Clamping hub with splined bore

SITEX® FL

Hub	Splines DIN 5480									
	Fig.	Splines type	A [mm]	B [mm]	C [mm]	G [mm]	h [mm]	L [mm]	Screw	Ms [Nm]
42	1	25 x 1.25 x 18	-	-	37	13	-	42	-	-
	3	25 x 1.25 x 18	-	-	37	13	-	42	M10	49
	6	30 x 2 x 14	60	6	37	13	-	42	M10	49
48	2	30 x 2 x 14	60	6	45	13	-	50	-	-
	6	30 x 2 x 14	60	6	45	13	-	50	M10	49
65	2	35 x 2 x 16	60	6	49	20	-	55	-	-
	6	35 x 2 x 16	60	6	54	20	-	60	M12	86
	2	40 x 2 x 18	78	6	49	20	-	55	-	-
	6	40 x 2 x 18	78	6	54	20	-	60	M12	86
	6	45 x 2 x 21	78	6	49	20	-	55	M12	86
80	3	50 x 2 x 24	-	-	49	25	-	55	M16	295

Hub	Splines SAE J498											
	Fig.	Splines type	Tooth	DP	A [mm]	B [mm]	C [mm]	h [mm]	G [mm]	L [mm]	Screw	Ms [Nm]
42	3	PH-S 5/8"	9	16/32	-	-	37	-	13	42	M10	49
	4	PI-S 3/4"	11	16/32	-	-	-	-	13	42	M10	49
	6	PB-S 7/8"	13	16/32	60	3	37	-	13	42	M10	49
	5	PB-BS 1"	15	16/32	50	6	37	27	13	42	M10	49
48	5	PA-S 1 3/8"	21	16/32	52	7	45	45	13	50	M10	49
65	5	PA-S 1 3/8"	21	16/32	52	5	49	48	20	55	M12	86
	5	PC-S 1 1/4"	14	12/24	52	5	49	44	20	55	M12	86
80	3	PE 1 3/4"	27	16/32	-	-	49	-	25	55	M16	295

Ms= clamp screws tightening torque  
Other splined bores and executions are available upon request.

## SITEX® FL coupling selection

### Motor side

Engine nominal power [kW]

Number of rotations at nominal power [rpm]

SAE dimension of the engine housing

Engine max torque [Nm]

Number of rotations [rpm]

Engine flywheel dimension

### Driven side

Type of the pump shaft (specify splined type, diameter and length)

Type of the pump flange

---